

Plas-Crete Force Protection Planters and Berms

Plas-Crete Force Protection Blocks are easily stacked and configured to create all types of protective planters and berm walls.

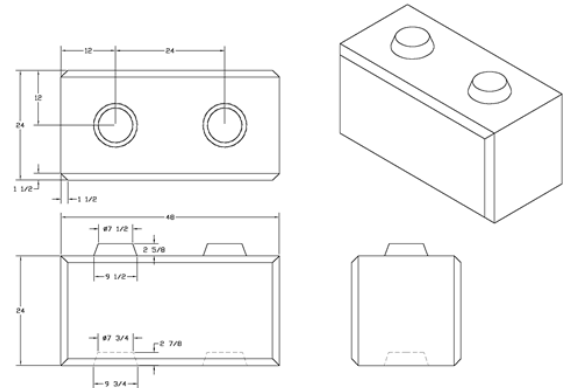

Protective Earth Berm retained by Plas-Crete Force Protection Blocks with Cut Stone Designer Finish. Once the berm is planted, an aesthetically pleasing force protection solution shall be complete!

Planter Wall built with Standard Finish Plas-Crete Force Protection Blocks and integrated into an Urban Water Garden.



701 Waverly Street, Framingham, MA 01702
 (888) CONIG - 25, fax (508) 653-6672
sales@conigliaro.com www.conigliaro.com

